



grindex

Heavy duty submersible slurry pumps



Slurry pumps:

- Bravo 200
- Bravo 300
- Bravo 400
- Bravo 500
- Bravo 600
- Bravo 700
- Bravo 800
- Bravo 900

50 Hz



Submersible slurry pumps for pumping fluids with abrasive solids

Pumping slurry is one of the most demanding applications for any pump. Parts wear out, maintenance and repair costs are high. In many cases, frequent pump failures lead to costly production downtime. Also, excessive sediment build-up in a sump costs time and money to remove.

With Grindex new slurry pump series, you have an effective solution to the rising costs of slurry handling: robust, hard-working pumps that lower operating and maintenance costs and offer excellent value in terms of initial investment.

Grindex, being a world leader in submersible pumps, has focused on solving these problems for years, developing slurry pumps that can handle the toughest, high-wear applications.



Why submersible?

The submersible concept offers numerous benefits over dry-mounted pumps. As it doesn't require any support superstructure, it requires less space for operation and is very easy to install. Being submersible means its flood-proof. Operating underwater also means quiet operation. On top of that, the time for maintenance can be greatly reduced.

The Bravo pumps are made to operate over the complete pump curve, not just one specific duty point. This means that the pump can be used in numerous applications within its range, instead of being "one pump - one application".





This is what makes our slurry pumps unique

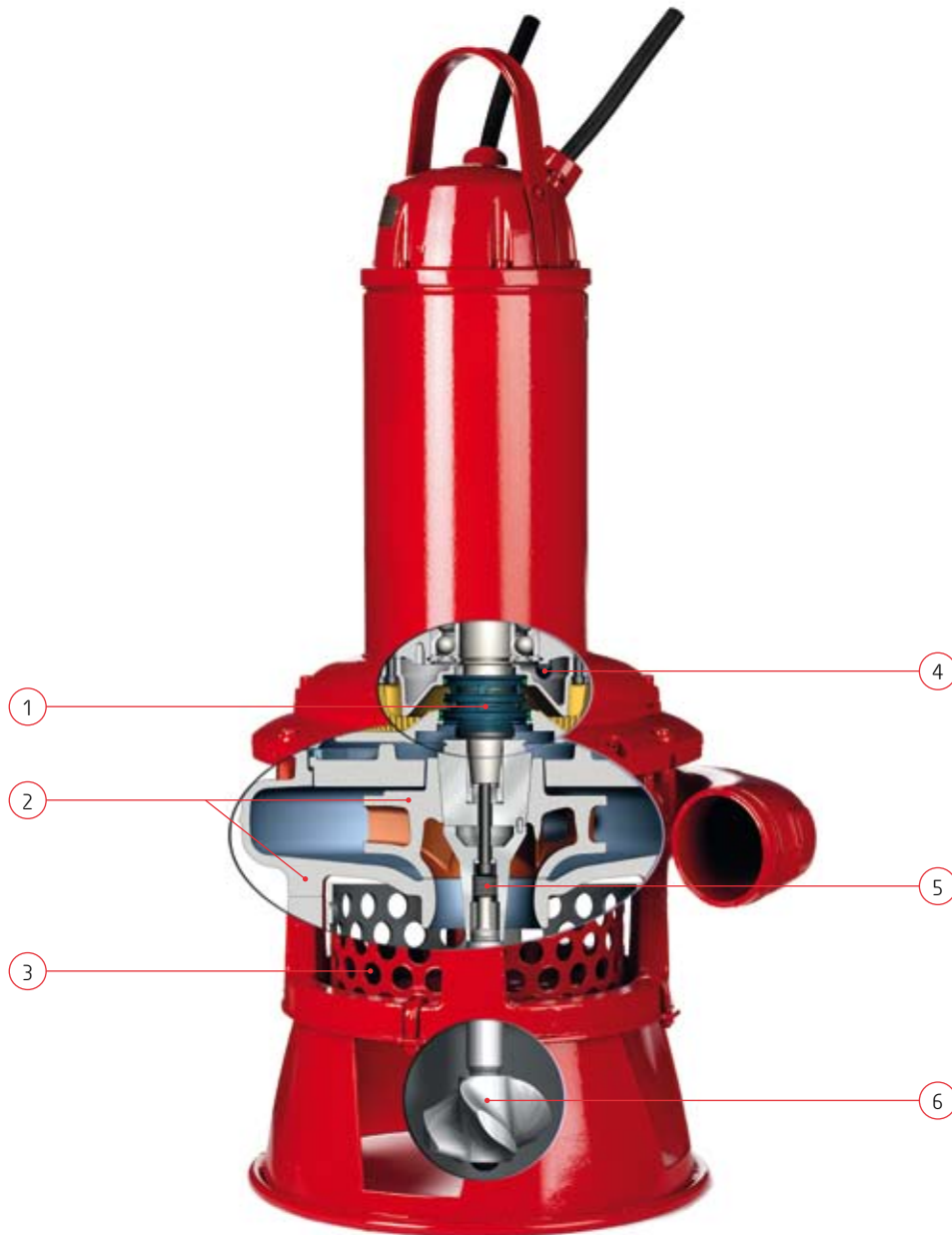

Bravo 400 - Bravo 900

1. Cartridge seal

Pre-assembled, faster and easier to mount

2. Impeller and pump housing made of Hard-iron™

Gives high wear resistance

3. Large throughlet

Handles solids of varying sizes

4. Leakage sensor

For early detection of any leakage

5. Single adjustment screw

Easy to adjust the impeller for optimal performance

6. Agitator for coarser slurries

Stirs up and pumps sand, sludge and solids in suspension



Typical Bravo applications

- Coal washing water
- Sump cleaning and cleaning of settling ponds
- Dredging
- Coal and ore slurries
- Grit removal in sewage treatments plants
- Cooling water/mill scale pumping in iron/steel production
- Bentonite pumping
- Various drainage applications in quarries and mines
- Nuisance slurry removal
- Secondary processes in other industries that require pumps with very high durability

Technical data

Pump type

Electrical submersible slurry pump

Classification

Protection class: IP 68

Max. submersion depth: 20 m

Power cable

SUBCAB, 20 m

Discharge connection

Hose or threaded (Bravo 200 – Bravo 300)

Victaulic® (Bravo 400 – Bravo 900)

Material

Drive unit: Cast iron

Suction cover (Bravo 200 – Bravo 300): Nitrile rubber

Pump housing (Bravo 200 – Bravo 300): Cast iron

Pump housing (Bravo 400 – Bravo 900): Hard-iron™

Hose connector (Bravo 200 – Bravo 300): Cast iron

Impeller: Hard- Iron™

Lifting handle (Bravo 200 – Bravo 300):

Galvanised steel

Lifting handle (Bravo 400 – Bravo 900):

Stainless steel

Shaft: Stainless steel

Agitator: Hard- Iron™

Studs, screws and nuts: Stainless steel

O-rings: Nitrile rubber

Option

Cooling jacket

Limitations

Max. submersion depth: 20 m (66 ft)

Max. liquid temperature: 40 °C (104 °F)

Allowed pH range: 5.5 – 13

Specifications can be changed without notice



HEAVY DUTY SLURRY PUMPS: BRAVO 400 – BRAVO 500 – BRAVO 600

BRAVO 400

Technical data

Discharge connection	4"
Rated output	14 kW
Max power consumption	16 kW
Shaft speed	1455 RPM
Rated current at 400 V	28 A
Rated current at 500 V	21 A
Throughlet	30 mm

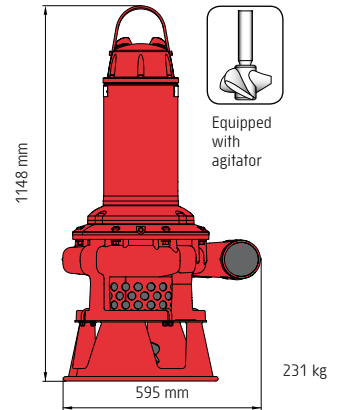
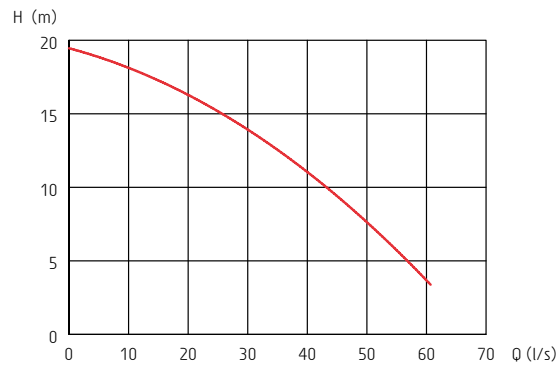

BRAVO 500

Technical data

Discharge connection	4"
Rated output	19 kW
Max power consumption	21 kW
Shaft speed	1460 RPM
Rated current at 400 V	36 A
Rated current at 500 V	29 A
Throughlet	40 mm

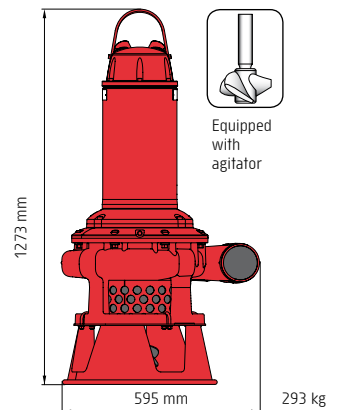
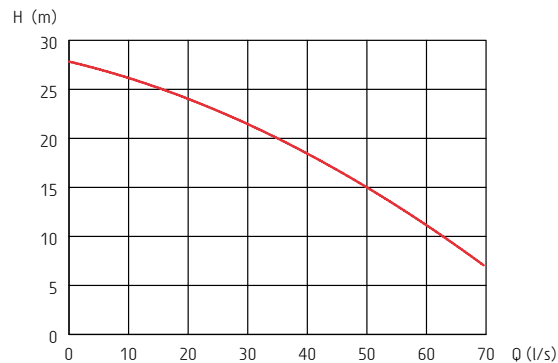

BRAVO 600

Technical data

Discharge connection	4"
Rated output	22 kW
Max power consumption	25 kW
Shaft speed	1460 RPM
Rated current at 400 V	41 A
Rated current at 500 V	33 A
Throughlet	40 mm

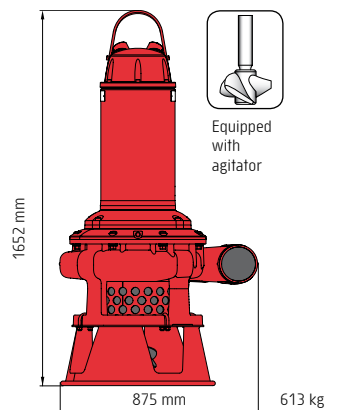
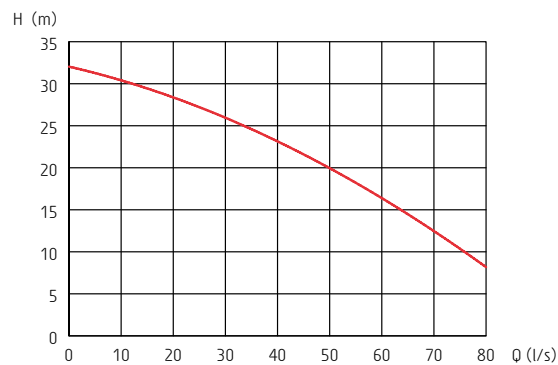



HEAVY DUTY SLURRY PUMPS: BRAVO 700 – BRAVO 800 – BRAVO 900

BRAVO 700

Technical data

Discharge connection	6"
Rated output	37 kW
Max power consumption	40 kW
Shaft speed	1475 RPM
Rated current at 400 V	66 A
Rated current at 500 V	54 A
Throughlet	36 mm

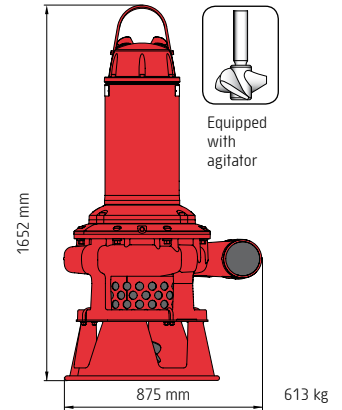
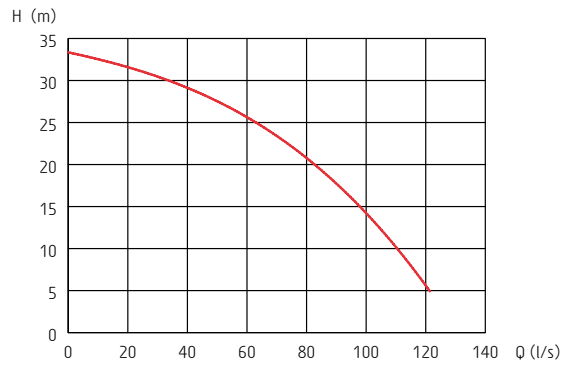

BRAVO 800

Technical data

Discharge connection	6"
Rated output	45 kW
Max power consumption	49 kW
Shaft speed	1475 RPM
Rated current at 400 V	82 A
Rated current at 500 V	63 A
Throughlet with/without agitator	36 mm

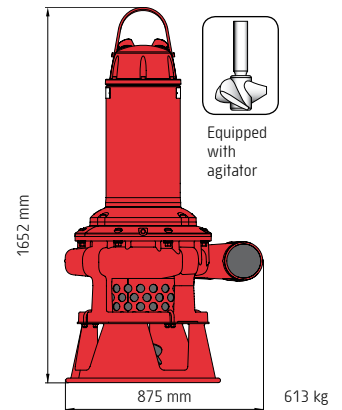
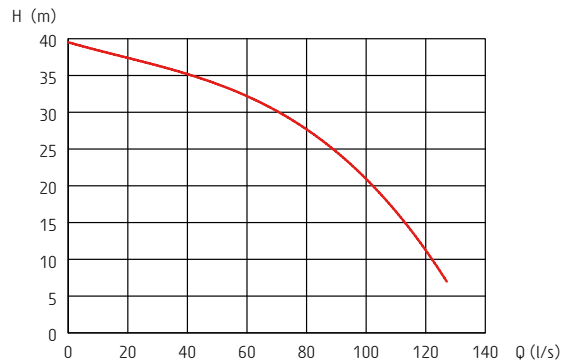

BRAVO 900

Technical data

Discharge connection	6"
Rated output	70 kW
Max power consumption	75 kW
Shaft speed	1475 RPM
Rated current at 400 V	132 A
Rated current at 500 V	102 A
Throughlet with/without agitator	36 mm

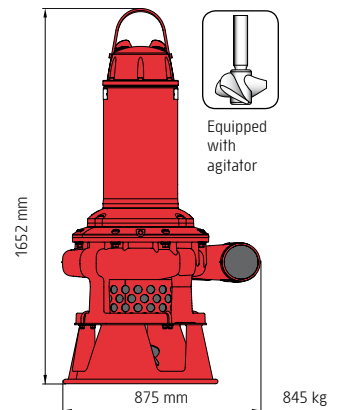
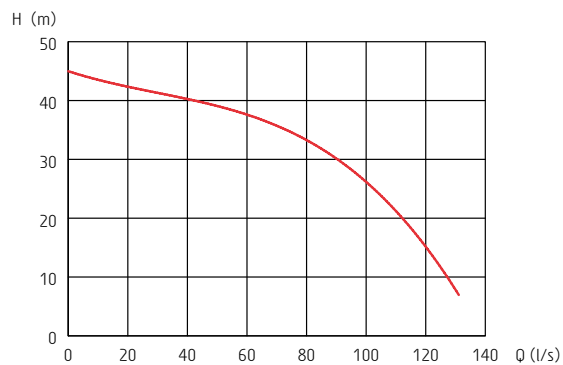



SLURRY PUMPS: BRAVO 200 – BRAVO 300

Smaller slurry pumps

All slurry applications don't require heavy duty pumps. To meet this demand, Grindex offer these two smaller models. They are intended for applications with lower demands on capacity and wear resistance. The pumps are not equipped with agitator.

For capacities below these, we recommend Grindex sludge pumps.

BRAVO 200

Technical data

Discharge connection	3-4"
Rated output	4,7 kW
Max power consumption	5,7 kW
Shaft speed	1445 RPM
Rated current at 400 V	9,6 A
Rated current at 500 V	7,7 A
Throughlet with	50 mm

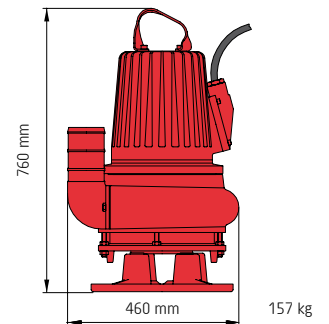
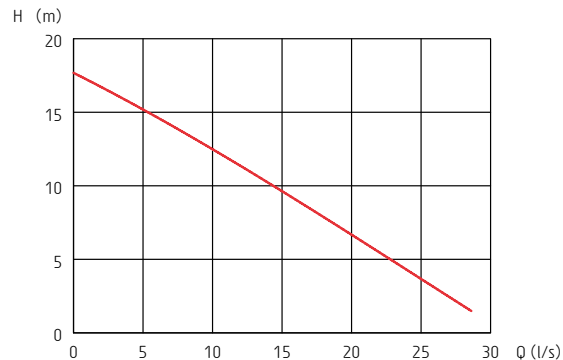

BRAVO 300

Technical data

Discharge connection	3-4"
Rated output	5,9 kW
Max power consumption	7,1 kW
Shaft speed	1450 RPM
Rated current at 400 V	12 A
Rated current at 500 V	9,5 A
Throughlet with	50 mm

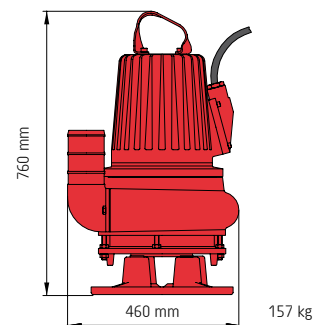
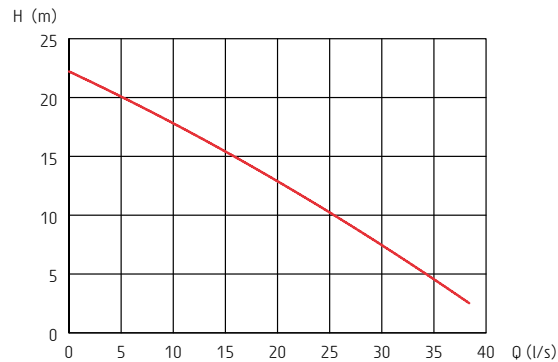



The Grindex team.

For some 50 years, Grindex has specialised in designing and manufacturing electrical submersible pumps for professionals. Durable and dependable, they are used in the most demanding and specialised applications worldwide. We have delivered over 300 000 pumps in more than 100 countries.

We offer pumps for almost any application. Our range includes drainage pumps, sludge pumps, slurry pumps and stainless steel pumps.

When you are running a Grindex pump, you can rest assured that a dedicated team is watching your back. Our experts are always there to see to your every need. Through our global network of sales and service centres, we provide the best level of support possible – day and night, seven days a week.

It's all part of the service.

For more information, please visit www.grindex.com

Grindex AB • Box 7025 • SE-174 07 Sundbyberg • Sweden • Tel +468 606 66 00 • Fax +468 745 53 28 • marketing@grindex.com



BAO BINH TECHNOLOGY CO., LTD

Address: 816/20 Truong Sa, Ward 14, District 3, HCMC, Vietnam.

Tel. +84 28 38420440 Fax. +84 28 38420460

www.bbtec.com.vn